

SECTION **FSU**
FRONT SUSPENSION

A
B
C
D
E
F
G
H
I
J
K
L
M
N
O
P

FSU

CONTENTS

PRECAUTION	2	Disposal	8
PRECAUTIONS	2	TRANSVERSE LINK	10
Precaution for Supplemental Restraint System (SRS) "AIR BAG" and "SEAT BELT PRE-TENSIONER"	2	Removal and Installation	10
General Precautions	2	FRONT STABILIZER	11
SYMPTOM DIAGNOSIS	3	Removal and Installation	11
NOISE, VIBRATION AND HARSHNESS (NVH) TROUBLESHOOTING	3	REMOVAL AND INSTALLATION	12
NVH Troubleshooting Chart	3	FRONT SUSPENSION ASSEMBLY	12
PREPARATION	4	Exploded View	12
PREPARATION	4	Removal and Installation	13
Special Service Tool	4	DISASSEMBLY AND ASSEMBLY	14
Commercial Service Tool	5	FRONT COIL SPRING AND STRUT	14
ON-VEHICLE MAINTENANCE	6	Disassembly and Assembly	14
FRONT SUSPENSION ASSEMBLY	6	Inspection	16
Inspection and Adjustment	6	SERVICE DATA AND SPECIFICATIONS (SDS)	17
ON-VEHICLE REPAIR	8	SERVICE DATA AND SPECIFICATIONS (SDS)	17
FRONT COIL SPRING AND STRUT	8	Front Wheel Alignment (Unladen*)	17
Removal and Installation	8	Ball Joint	17
		Wheelarch Height (Unladen*)	17

PRECAUTIONS

< PRECAUTION >

PRECAUTION

PRECAUTIONS

Precaution for Supplemental Restraint System (SRS) "AIR BAG" and "SEAT BELT PRE-TENSIONER"

INFOID:000000005809646

The Supplemental Restraint System such as "AIR BAG" and "SEAT BELT PRE-TENSIONER", used along with a front seat belt, helps to reduce the risk or severity of injury to the driver and front passenger for certain types of collision. This system includes seat belt switch inputs and dual stage front air bag modules. The SRS system uses the seat belt switches to determine the front air bag deployment, and may only deploy one front air bag, depending on the severity of a collision and whether the front occupants are belted or unbelted. Information necessary to service the system safely is included in the SR and SB section of this Service Manual.

WARNING:

- To avoid rendering the SRS inoperative, which could increase the risk of personal injury or death in the event of a collision which would result in air bag inflation, all maintenance must be performed by an authorized NISSAN/INFINITI dealer.
- Improper maintenance, including incorrect removal and installation of the SRS, can lead to personal injury caused by unintentional activation of the system. For removal of Spiral Cable and Air Bag Module, see the SR section.
- Do not use electrical test equipment on any circuit related to the SRS unless instructed to in this Service Manual. SRS wiring harnesses can be identified by yellow and/or orange harnesses or harness connectors.

PRECAUTIONS WHEN USING POWER TOOLS (AIR OR ELECTRIC) AND HAMMERS

WARNING:

- When working near the Airbag Diagnosis Sensor Unit or other Airbag System sensors with the Ignition ON or engine running, DO NOT use air or electric power tools or strike near the sensor(s) with a hammer. Heavy vibration could activate the sensor(s) and deploy the air bag(s), possibly causing serious injury.
- When using air or electric power tools or hammers, always switch the Ignition OFF, disconnect the battery, and wait at least 3 minutes before performing any service.

General Precautions

INFOID:000000005440803

- When installing rubber bushings, the final tightening must be carried out under unladen conditions with tires on ground. Oil might shorten the life of rubber bushings. Be sure to wipe off any spilled oil.
- Unladen conditions mean that fuel, engine coolant and lubricant are full. Spare tire, jack, hand tools and mats are in designated positions.
- After servicing suspension parts, be sure to check wheel alignment.
- Self-lock nuts are not reusable. Always use new ones when installing. Since new self-lock nuts are pre-oiled, tighten as they are.

NOISE, VIBRATION AND HARSHNESS (NVH) TROUBLESHOOTING

< SYMPTOM DIAGNOSIS >

SYMPTOM DIAGNOSIS

NOISE, VIBRATION AND HARSHNESS (NVH) TROUBLESHOOTING

NVH Troubleshooting Chart

INFOID:000000005440800

Use the chart below to help you find the cause of the symptom. If necessary, repair or replace these parts.

Symptom		Possible cause and SUSPECTED PARTS												
		Improper installation, looseness	Shock absorber deformation, damage or deflection	Bushing or mounting deterioration	Parts interference	Spring fatigue	Suspension looseness	Incorrect wheel alignment	Stabilizer bar fatigue	TIRES	ROAD WHEEL	DRIVE SHAFT AND WHEEL HUB	BRAKES	STEERING
Symptom	Noise	x	x	x	x	x	x			x	x	x	x	x
	Shake	x	x	x	x		x			x	x	x	x	x
	Vibration	x	x	x	x	x				x		x		x
	Shimmy	x	x	x	x			x		x	x		x	x
	Shudder	x	x	x						x	x		x	x
	Poor quality ride or handling	x	x	x	x	x		x	x	x	x			
Reference page		FSU-12	FSU-16	—	—	—	FSU-12	FSU-6	FSU-6	WT-55. "NVH Troubleshooting Chart"	WT-55. "NVH Troubleshooting Chart"	FAX-3. "NVH Troubleshooting Chart"	BR-6. "NVH Troubleshooting Chart"	ST-3. "NVH Troubleshooting Chart"

x: Applicable

A
B
C
D
E
F
G
H
I
J
K
L
M
N
O
P

FSU

PREPARATION

< PREPARATION >

PREPARATION

PREPARATION

Special Service Tool

INFOID:000000005809638

The actual shapes of the Kent-Moore tools may differ from those of special service tools illustrated here.

Tool number (Kent-Moore No.) Tool name	Description
HT7252000 (J-25730-A) Ball joint remover	Removing tie-rod outer and lower ball joint
ST3127S000 (J-25765-A) Preload gauge	Measuring ball joint rotating torque
KV991040S1 (—) CCK gauge attachment <ol style="list-style-type: none"> 1. KV99104020 Adapter A 2. KV99104030 Adapter B 3. KV99104040 Adapter C 4. KV99104050 Adapter D 5. KV99104060 Plate 6. KV99104070 Guide bolt 7. KV99104080 Spring 8. KV99104090 Center plate 	Measuring wheel alignment
ST35652000 (—) Strut attachment	Disassembling and assembling strut
KV101J0010 (J-47242) Engine support table	Front suspension member removal

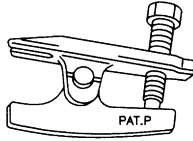

S-NT146

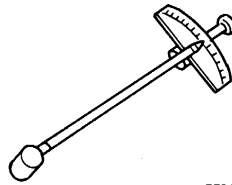

ZZA0806D

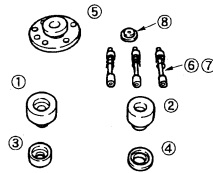

ZZA1167D

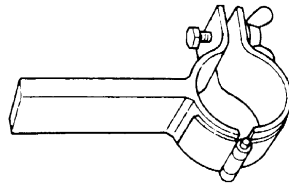

ZZA0807D

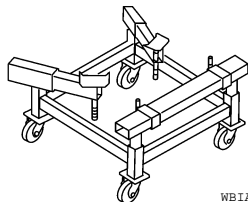

WBIA0658E

PREPARATION

< PREPARATION >

Tool number (Kent-Moore No.) Tool name	Description	A
— (J-49286) Drift and Pull gauge	Measuring drift and pull	B C
— (J-49029) Strut rod clamp	Securing strut rod	D <div style="background-color: black; color: white; padding: 2px; text-align: center;">FSU</div> F

Commercial Service Tool

INFOID:000000005440805

Tool name	Description	G
Power tool	Loosening bolts and nuts	H I J
Spring compressor	Removing and installing coil spring	K L M N O P

FRONT SUSPENSION ASSEMBLY

< ON-VEHICLE MAINTENANCE >

ON-VEHICLE MAINTENANCE

FRONT SUSPENSION ASSEMBLY

Inspection and Adjustment

INFOID:000000005440806

INSPECTION

Make sure the mounting conditions (looseness, back lash) of each component and component conditions (wear, damage) are normal.

LOWER BALL JOINT END PLAY

1. Set front wheels in a straight-ahead position. Do not depress brake pedal.
2. Place an iron bar or similar tool between upper link and steering knuckle.
3. Measure axial end play by prying it up and down. Refer to [FSU-17, "Ball Joint"](#).

CAUTION:

Be careful not to damage ball joint boot. Do not damage the installation position by applying excessive force.

SHOCK ABSORBER

Check for oil leakage, damage and replace if malfunction is detected.

WHEEL ALIGNMENT

Description

Measure wheel alignment under unladen conditions.

NOTE:

"Unladen conditions" means that fuel, engine coolant, and lubricant are full. Spare tire, jack, hand tools and mats are in designated positions.

General Information and Recommendations

- A four-wheel thrust alignment should be performed.
- This type of alignment is recommended for any NISSAN vehicle.
- The four-wheel "thrust" process helps ensure that the vehicle is properly aligned and the steering wheel is centered.
- The alignment rack itself should be capable of accepting any NISSAN vehicle.
- The rack should be checked to ensure that it is level.
- Make sure the machine is properly calibrated.
- Your alignment equipment should be regularly calibrated in order to give correct information.
- Check with the manufacturer of your specific equipment for their recommended Service/Calibration Schedule.

Preliminary Check

Check the following:

1. Tires for improper air pressure and wear.
2. Road wheels for runout. Refer to [WT-64, "Road Wheel"](#).
3. Wheel bearing axial end play. Refer to [FAX-5, "Inspection"](#).
4. Transverse link ball joint axial end play. Refer to [FSU-17, "Ball Joint"](#).
5. Shock absorber operation.
6. Each mounting part of axle and suspension for looseness and deformation.
7. Each of suspension member, shock absorber, upper link and transverse link for cracks, deformation and other damage.
8. Vehicle height (posture).

Alignment Process

IMPORTANT:

Use only the alignment specifications listed in this Service Manual.

- When displaying the alignment settings, many alignment machines use "indicators" **Do not use these indicators.:** (Green/red, plus or minus, Go/No Go).
- The alignment specifications programmed into your machine that operate these indicators may not be correct.

FRONT SUSPENSION ASSEMBLY

< ON-VEHICLE MAINTENANCE >

- This may result in an ERROR.
- Some newer alignment machines are equipped with an optional "Rolling Compensation" method to "compensate" the sensors (alignment targets or head units). Do not use this "Rolling Compensation" method.
- Use the "Jacking Compensation Method". After installing the alignment targets or head units, raise the vehicle and rotate the wheels 1/2 turn both ways.
- See Instructions in the alignment machine you're using for more information on this.

A
B
C
D

ADJUSTMENT

Camber, Caster and Kingpin Inclination Angles

CAUTION:
Camber, caster, kingpin inclination angles cannot be adjusted.

FSU

F
G
H
I
J
K
L
M
N
O
P

FRONT COIL SPRING AND STRUT

< ON-VEHICLE REPAIR >

ON-VEHICLE REPAIR

FRONT COIL SPRING AND STRUT

Removal and Installation

INFOID:000000005809641

REMOVAL

1. Remove wheel and tire using power tool. Refer to [WT-60, "Adjustment"](#).
2. Remove brake caliper and reposition aside using wire. Refer to [BR-30, "BRAKE CALIPER ASSEMBLY : Removal and Installation"](#).

CAUTION:

Avoid depressing brake pedal with brake caliper removed.

3. Remove stabilizer bar connecting rod end from strut. Refer to [FSU-12, "Exploded View"](#).
4. Remove wheel sensor electrical harness from strut. Refer to [BRC-198, "Removal and Installation"](#).
5. Remove brake hose lock plate.
6. Remove steering knuckle to strut bolts and nuts. Refer to [FSU-12, "Exploded View"](#).
7. Remove bolt on strut tower bar then bolts on strut tower and remove strut from vehicle.

INSPECTION AFTER REMOVAL

Check the strut for any oil leakage or other damage and replace as necessary.

INSTALLATION

Installation is in the reverse order of removal.

- Refer to [FSU-12, "Exploded View"](#) for tightening torque.
- Be sure tab (A) on strut mount insulator is positioned as shown.

(A) : Tab

⇐ : Vehicle front

- Check wheel alignment. Refer to [FSU-6, "Inspection and Adjustment"](#).

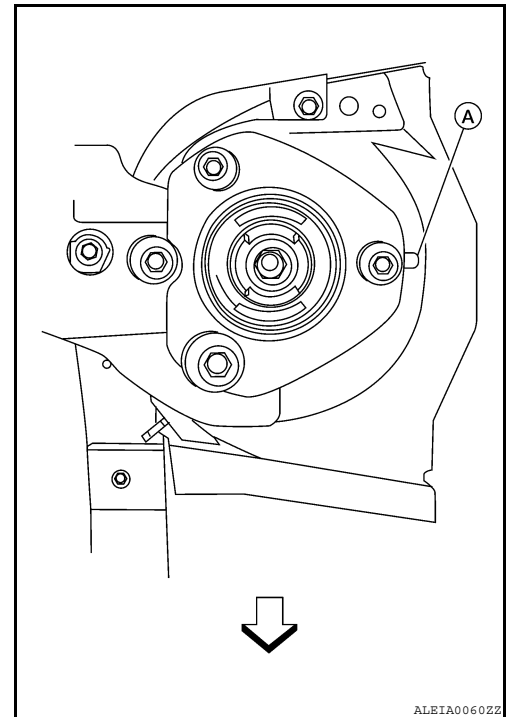

INFOID:000000005809642

Disposal

1. Set strut assembly horizontally with the piston rod fully extended.

FRONT COIL SPRING AND STRUT

< ON-VEHICLE REPAIR >

2. Drill 2 – 3 mm (0.08 – 0.12 in) hole at the position (●) from top as shown in the figure to release gas gradually.

CAUTION:

- **Wear eye protection (safety glasses).**
- **Wear gloves.**
- **Be careful with metal chips or oil blown out by the compressed gas.**

NOTE:

- Drill vertically in this direction (←).
- Directly to the outer tube avoiding brackets.
- The gas is clear, colorless, odorless, and harmless.

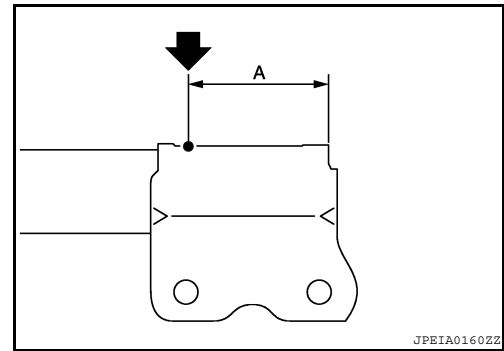

(A) : 20 – 30 mm (0.79 – 1.18 in)

3. Position the drilled hole downward and drain oil by moving the piston rod several times.

CAUTION:

Dispose of drained oil according to the law and local regulations.

A
B
C
D

FSU

F
G
H
I
J
K
L
M
N
O
P

TRANSVERSE LINK

< ON-VEHICLE REPAIR >

TRANSVERSE LINK

Removal and Installation

INFOID:000000005440810

REMOVAL

1. Remove wheel and tire using power tool. Refer to [WT-60, "Adjustment"](#).
2. Remove steering knuckle and hub assembly. Refer to [FAX-7, "Removal and Installation"](#).
3. Remove transverse link mounting bolts and nuts, and remove transverse link from suspension member.

INSPECTION AFTER REMOVAL

Visual Inspection

Check transverse link and bushing for deformation, cracks, and other damage. Replace the entire transverse link assembly if cracks, deformation or any other damage is found.

Ball Joint Inspection

CAUTION:

Before measurement, move the ball joint at least ten times by hand to check for smooth movement.

Swing Torque Inspection

- Hook Tool (B) at cotter pin mounting hole (A). Confirm Tool (B) measurement value is within specifications when ball stud begins moving.

⇐: Front

Tool number : — (J-44372)

Swing torque : 0.50 - 3.4 N·m (0.06 - 0.34 kg·m, 5 - 30 in·lb)

Measurement on Tool : 7.94 - 53.97 N (0.81 - 5.50 kg, 1.79 - 12.2 lb)

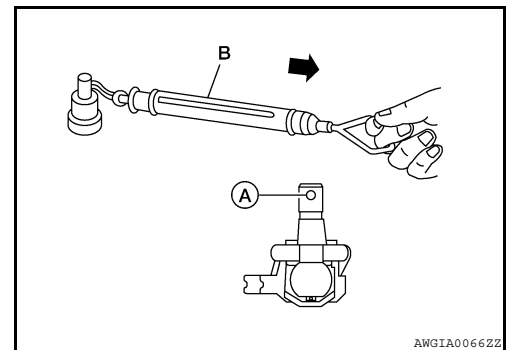

- If the value is outside the standard, replace transverse link.

Rotating Torque Inspection

- Attach mounting nut to ball stud. Check that rotating torque is within specifications using Tool.

Tool number : ST3127S000 (J-25765-A)

Rotating torque : 0.50 - 3.4 N·m (0.06 - 0.34 kg·m, 5 - 30 in·lb)

- If the value is outside the standard, replace transverse link.

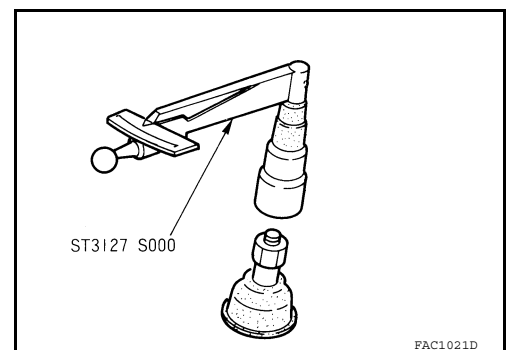

Axial End Play Inspection

- Move tip of ball joint in axial direction to check for looseness.

Axial end play : 0.1 mm (0.004 in) or less

- If any looseness is noted, replace transverse link.

INSTALLATION

Installation is in the reverse order of removal.

- Refer to [FSU-12, "Exploded View"](#) for tightening torque specifications.
- Tighten transverse link mounting bolts with vehicle unladen and all four tire on flat, level ground.
- After installation, check the wheel alignment. Refer to [FSU-6, "Inspection and Adjustment"](#).

FRONT STABILIZER

< ON-VEHICLE REPAIR >

FRONT STABILIZER

Removal and Installation

INFOID:000000005440811

REMOVAL

1. Remove steering gear. Refer to [ST-11, "Removal and Installation"](#).
2. Remove the stabilizer connecting rod nuts from the strut.

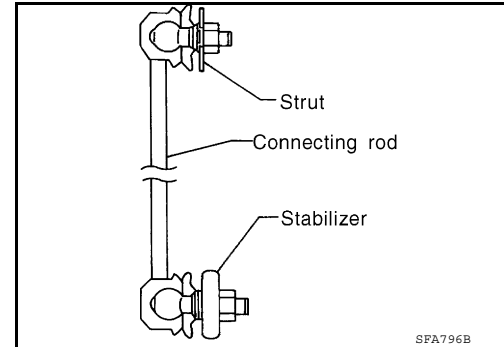

3. Remove stabilizer clamp bolts.
4. Remove stabilizer bar.

INSPECTION AFTER REMOVAL

Check stabilizer bar, connecting rod, bushing and clamp for deformation, cracks and damage, and replace as necessary.

INSTALLATION

Installation is in the reverse order of removal. Refer to [FSU-12, "Exploded View"](#) for tightening torque specifications.

- When installing stabilizer bar, make sure that the clamps are facing in the direction as shown.
- Make sure the cut surface of the stabilizer bushing faces the rear of the vehicle.

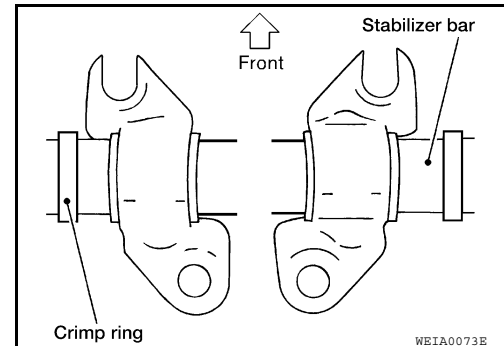

- Stabilizer bar uses pillow ball type connecting rod. Position ball joint with case on pillow ball head parallel to stabilizer as shown.

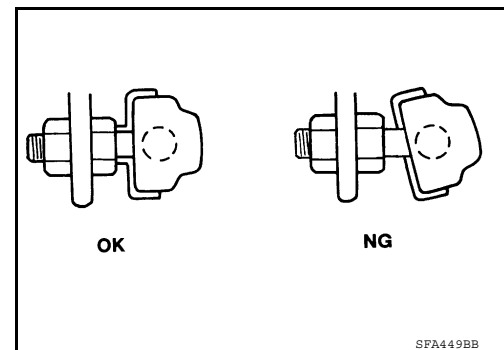

- Adjust toe. Refer to [FSU-6, "Inspection and Adjustment"](#).

FRONT SUSPENSION ASSEMBLY

< REMOVAL AND INSTALLATION >

REMOVAL AND INSTALLATION

FRONT SUSPENSION ASSEMBLY

Exploded View

INFOID:000000005440812

SEC. 400 • 401 • 406

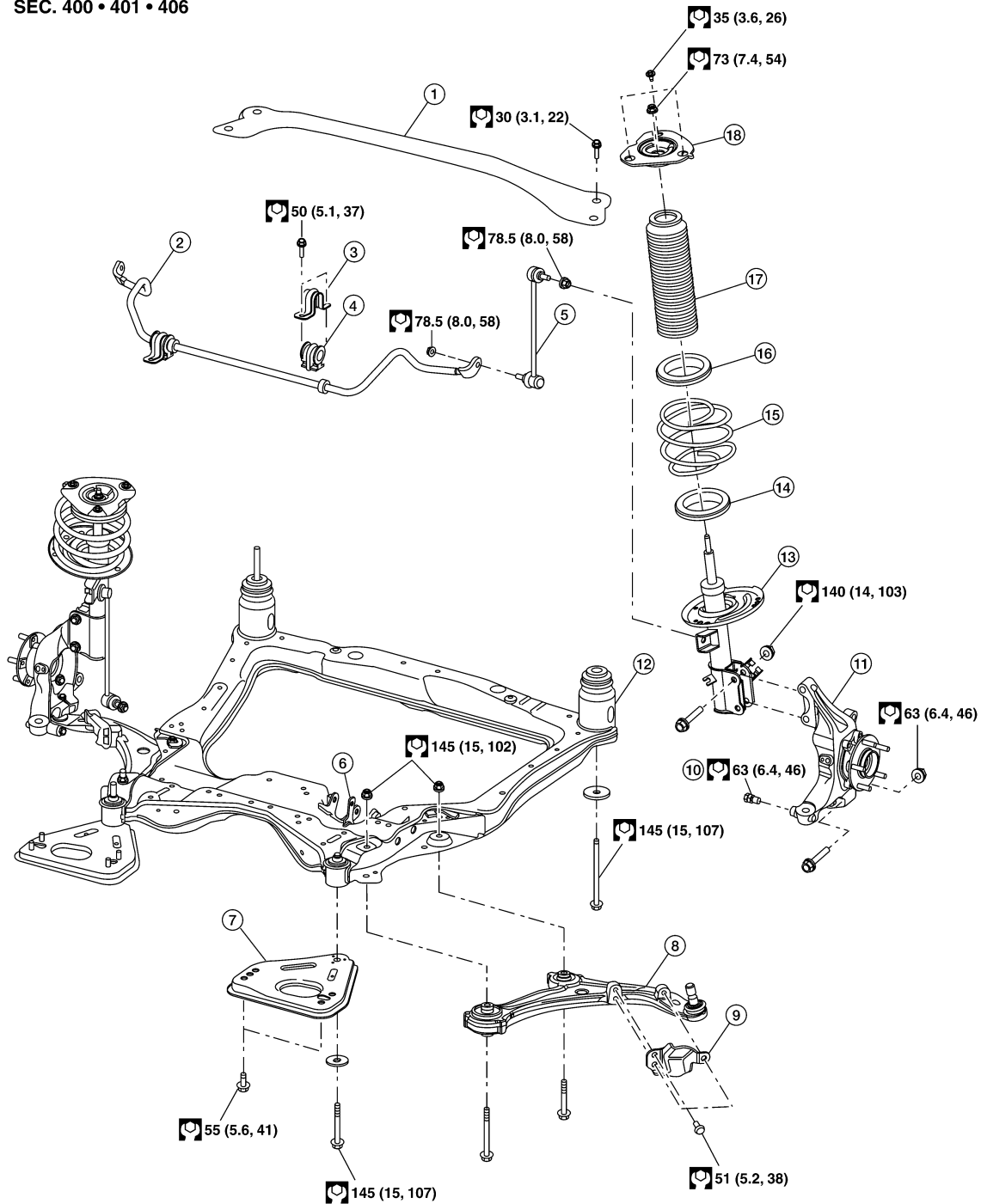

AWEIA0001GB

FRONT SUSPENSION ASSEMBLY

< REMOVAL AND INSTALLATION >

- | | | |
|-----------------------|-----------------------|-----------------------------|
| 1. Strut tower bar | 2. Stabilizer bar | 3. Stabilizer clamp |
| 4. Stabilizer bushing | 5. Connecting rod | 6. Engine mount bracket |
| 7. Member pin stay | 8. Transverse link | 9. Steering stop plate |
| 10. Steering stop | 11. Steering knuckle | 12. Front suspension member |
| 13. Strut | 14. Lower rubber seat | 15. Coil spring |
| 16. Upper rubber seat | 17. Dust cover | 18. Strut mount insulator |

Removal and Installation

INFOID:000000005440813

REMOVAL

The engine and transaxle are removed as an assembly mounted to the front suspension member. Refer to [EM-71. "Removal and Installation"](#). Once removed as an assembly, remove the front suspension member from the engine and transaxle assembly.

INSTALLATION

Installation is in the reverse order of removal.

- Refer to [FSU-12. "Exploded View"](#) for tightening torque specifications.
- After installation, perform final tightening of each part under unladen conditions with tires on ground.
- Check wheel alignment. Refer to [FSU-6. "Inspection and Adjustment"](#).

A
B
C
D
E
F
G
H
I
J
K
L
M
N
O
P

FSU

FRONT COIL SPRING AND STRUT

< DISASSEMBLY AND ASSEMBLY >

DISASSEMBLY AND ASSEMBLY

FRONT COIL SPRING AND STRUT

Disassembly and Assembly

INFOID:000000005819369

DISASSEMBLY

1. Install Tool (A) to strut and secure it in a vise.

Tool number (A) : ST35652000 (—)

CAUTION:

When installing Tool, wrap a shop cloth around strut to protect it from damage.

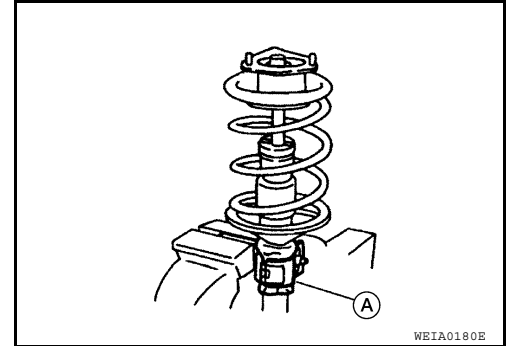

2. Install Tool to strut rod.

Tool number : — (J-49029)

3. Slightly loosen piston rod lock nut.

WARNING:

Do not remove piston rod lock nut completely. If it is removed completely, the coil spring can jump out and may cause serious damage or injury.

4. Compress coil spring using a commercially available spring compressor.

WARNING:

Make sure that the pawls of the two spring compressors are firmly hooked on the spring. The spring compressors must be tightened alternately so as not to tilt the spring.

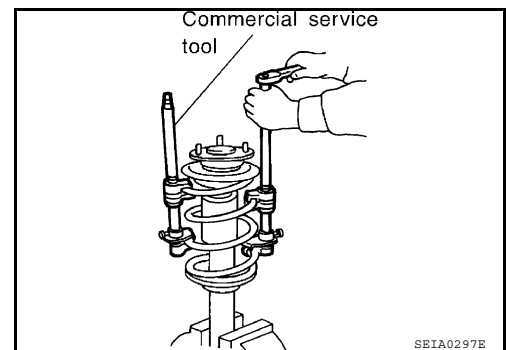

5. Making sure coil spring is free between upper and lower seats, then remove piston rod lock nut.
6. Remove small parts on strut.
 - Remove strut spacer, strut mount insulator, strut mounting insulator bracket thrust bearing, spring upper seat, and upper rubber seat. Then remove coil spring.
7. Remove bound bumper from spring upper seat.
8. Gradually release spring compressor (commercial service tool), and remove coil spring.

ASSEMBLY

FRONT COIL SPRING AND STRUT

< DISASSEMBLY AND ASSEMBLY >

1. Compress coil spring using a spring compressor (commercial service tool), and install it onto the strut.

WARNING:

Be sure spring compressor is securely attached to coil spring. Compress coil spring.

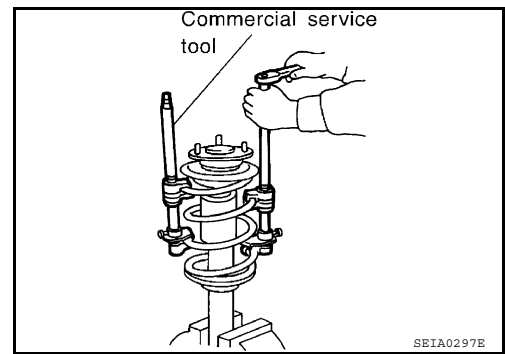

CAUTION:

Face tube side of coil spring downward. Align lower end to spring seat as shown.

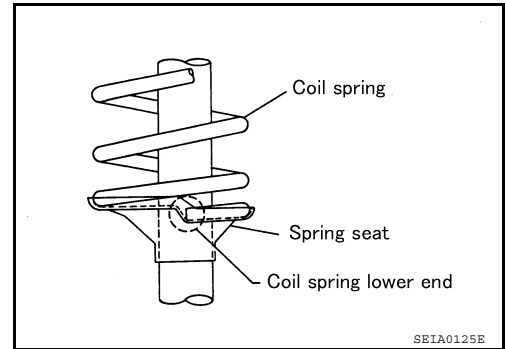

2. Connect bound bumper to spring upper seat.

CAUTION:

- Be sure to install bound bumper to spring upper seat securely.
- When installing bound bumper, use soapy water. Do not use machine oil or other lubricants.

3. Install small parts to the strut.

- Connect upper rubber seat, spring upper seats, thrust bearing, strut mount insulator, and strut spacer. Temporarily install piston rod lock nut.

CAUTION:

Do not reuse piston rod lock nut.

4. Be sure tab (A) on strut mount insulator is positioned as shown.

(A) : Tab

← : Vehicle front

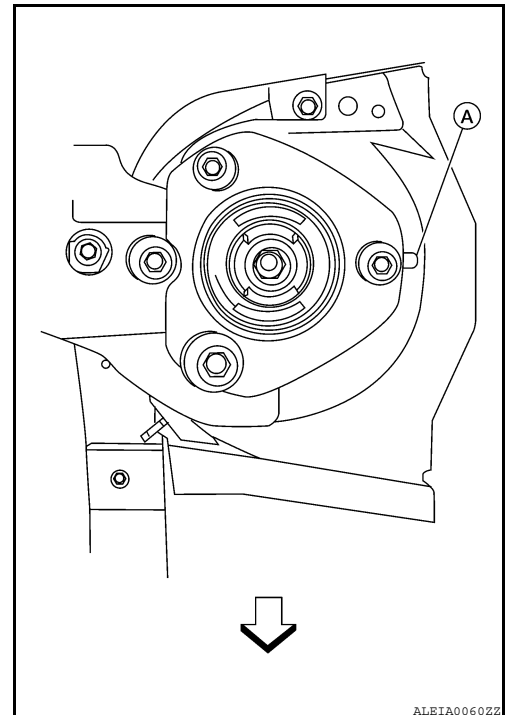

FRONT COIL SPRING AND STRUT

< DISASSEMBLY AND ASSEMBLY >

5. Be sure coil spring is properly set in spring rubber seat. Gradually release spring compressor.

CAUTION:

Be sure upper rubber seat is properly aligned to spring upper seat and coil spring.

6. Tighten piston rod lock nut to the specified torque. Refer to [FSU-12. "Exploded View"](#).

7. Remove Tool from strut.

Tool number (A) : ST35652000 (—)

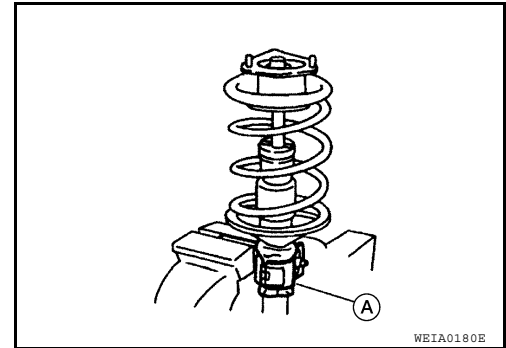

8. Remove Tool from strut rod.

Tool number : — (J-49029)

Inspection

INFOID:000000005809645

INSPECTION AFTER DISASSEMBLY

Strut

- Check strut for deformation, cracks, and damage, and replace if necessary.
- Check piston rod for damage, uneven wear, and distortion, and replace if necessary.
- Check welded and sealed areas for oil leakage, and replace if necessary.

Insulator and Rubber Parts

Check strut mount insulator for cracks and rubber parts for wear. Replace them if necessary.

Coil Spring

Check for cracks, wear, and damage, and replace if necessary.

SERVICE DATA AND SPECIFICATIONS (SDS)

< SERVICE DATA AND SPECIFICATIONS (SDS)

SERVICE DATA AND SPECIFICATIONS (SDS)

SERVICE DATA AND SPECIFICATIONS (SDS)

Front Wheel Alignment (Unladen*)

INFOID:000000005440814

Camber* Degree minute (decimal degree)	LH	Minimum	-1° 09' (-1.15°)	
		Nominal	-0° 24' (-0.40°)	
		Maximum	0° 21' (0.35°)	
	RH	Minimum	-1° 24' (-1.40°)	
		Nominal	-0° 39' (-0.65°)	
		Maximum	0° 06' (0.10°)	
Right and left difference		-0° 15' ± 0° 33' (-0.25° ± 0.55°)		
Caster* Degree minute (decimal degree)	Nominal	5° 00' (5.00°)		
	Right and left difference	0° 33' (0.55°)		
Kingpin offset* Degree minute (decimal degree)	Minimum	11° 48' (11.80°)		
	Nominal	12° 33' (12.55°)		
	Maximum	13° 18' (13.30°)		
Total toe-in* Degree minute (decimal degree)	Distance	Minimum	0 mm (0 in)	
		Nominal	1 mm (0.04 in)	
		Maximum	2 mm (0.08 in)	
	Angle (right side or left side)	Minimum	0° 01' (0.017°)	
		Nominal	0° 03' (0.050°)	
		Maximum	0° 05' (0.083°)	
Wheel turning angle*	Refer to ST-16, "Steering Angle" .			

* : Fuel, radiator coolant and engine oil full. Spare tire, jack, hand tools and mats in designated positions.

Ball Joint

INFOID:000000005440815

Swing torque	0.50 - 3.4 N-m (0.06 - 0.34 kg-m, 5 - 30 in-lb)
Measurement on tool	7.94 - 53.97 N (0.81 - 5.50 kg, 1.79 - 12.2 lb)
Rotating torque	0.50 - 3.4 N-m (0.06 - 0.34 kg-m, 5 - 30 in-lb)
Axial endplay	0.1 mm (0.004 in) or less

Wheelarch Height (Unladen*)

INFOID:000000005440816

Unit: mm (in)

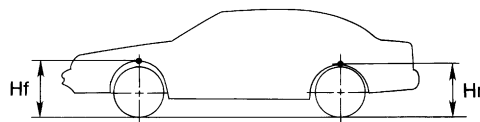

SFA818A

Destination	USA	Canada
Tire size	215/60R16	215/60R16

SERVICE DATA AND SPECIFICATIONS (SDS)

< SERVICE DATA AND SPECIFICATIONS (SDS)

Front (Hf)*	727 (28.62)	728 (28.66)
Rear (Hr)*	719 (28.31)	719 (28.31)

*: Fuel, engine coolant and engine oil full. Spare tire, jack, hand tools and mats in designated positions.